

ASEPT™

The Dispensing
Specialist

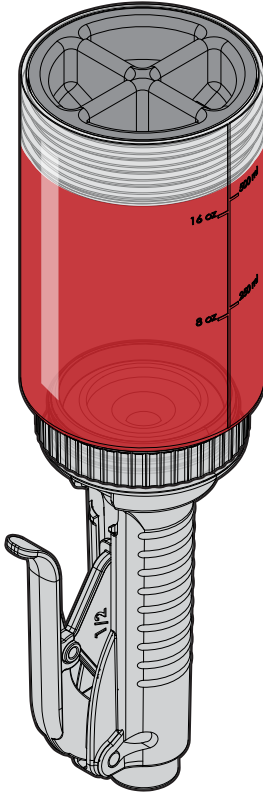

PORTION PUMP MAX

User Manual

Portion Pump Max

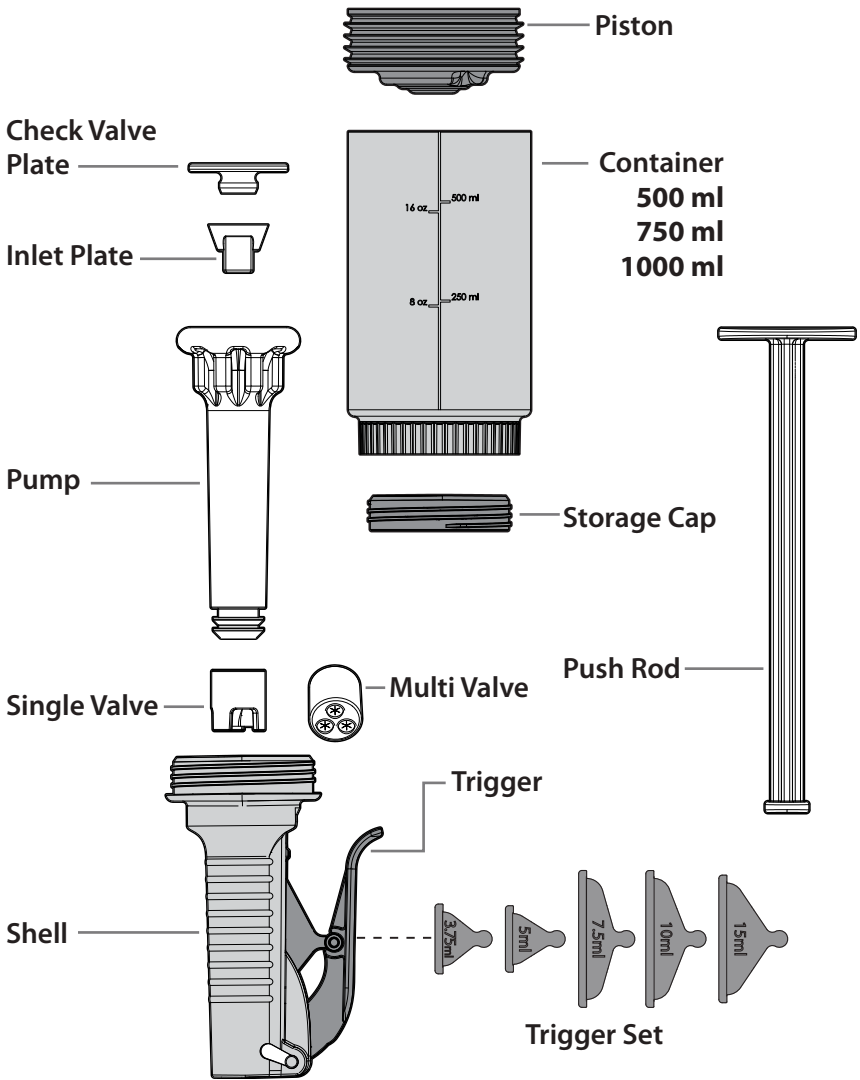

Safety

According to food and safety regulations, most foods must be stored and/or served at certain temperatures or they could become hazardous.



Check with local food and safety regulators for specific guidelines. Be aware of the product you are serving and the temperature the product is required to maintain.

Cleaning

All components must be cleaned before first use.

Disassemble all parts. Clean with soap and hot water, rinse, sanitize and dry according to local sanitization requirements.

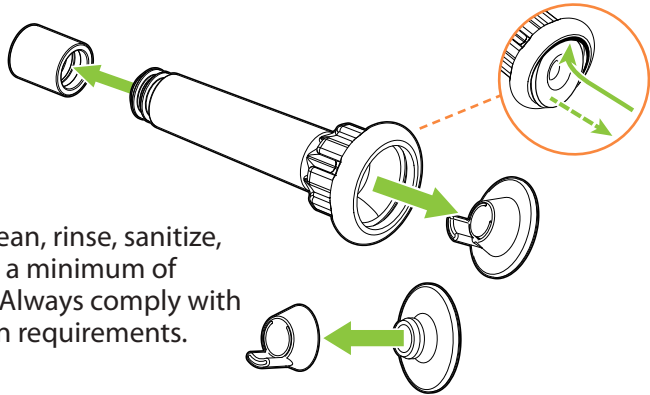

IMPORTANT Clean, rinse, sanitize, and dry parts at a minimum of every 24 hours. Always comply with local sanitization requirements.

3-SINK CLEANING PROGRAM HAND DISHWASHING & SANITIZING

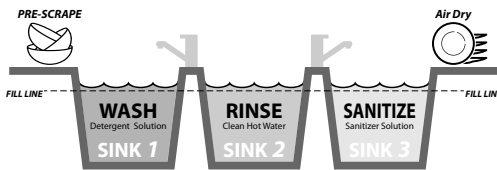

All pump components are dishwasher safe.



Cleaning

1

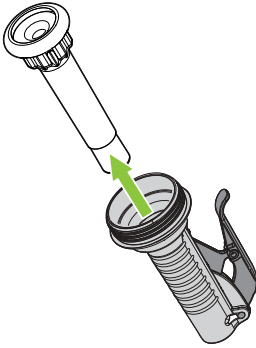

Remove
pump from housing.

2

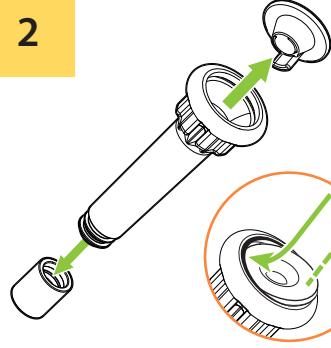

Remove
valve assembly and inlet valve from pump. Remove portion valve.

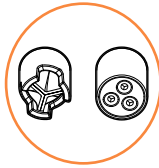

Take care when cleaning to prevent damage to nozzle opening(s).
Do not use sharp items.

3

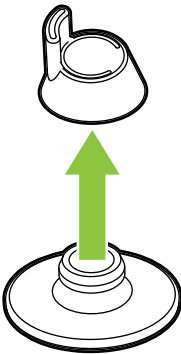

Remove
valve from valve base.

Use push rod to push piston out of container.

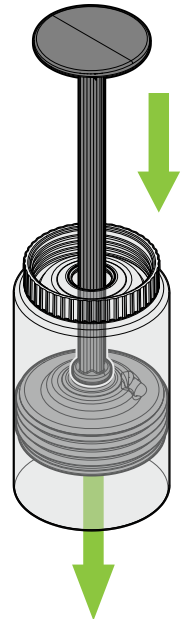

Assembly

1

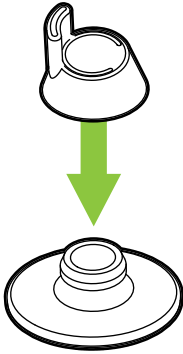

Assemble

inlet valve onto check valve plate.

2

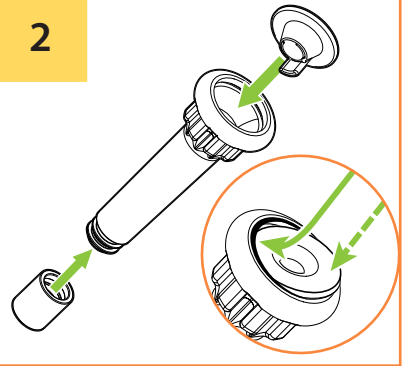

Insert

valve assembly into top of pump with inlet valve facing into the pump. Insert portion valve into end of pump.

3

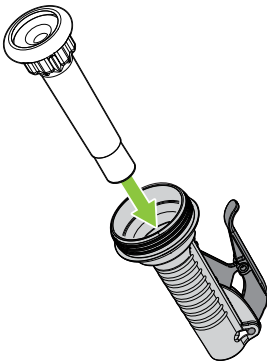

Insert

pump assembly into shell assembly.

4

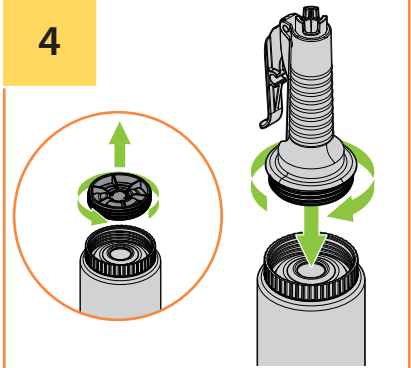

Remove

storage cap from container. Thread portion pump onto container until snug.

Filling the Container

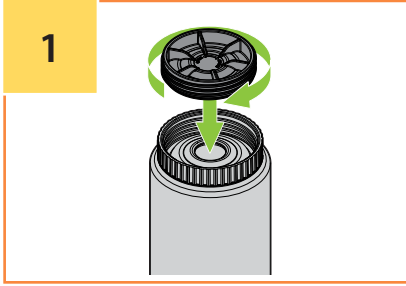

1 Thread

storage cap onto container.

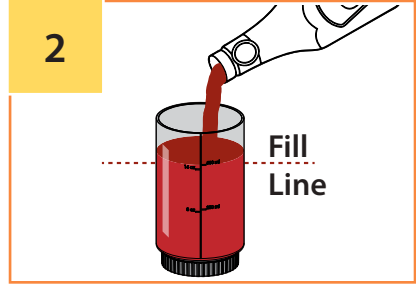

2 Pour

product into container to capacity line.

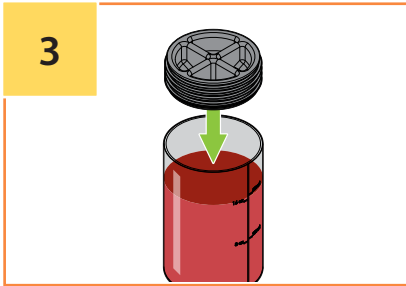

3 Press

piston into container and push down until all air is expelled through the vent. Invert and store until ready to use.

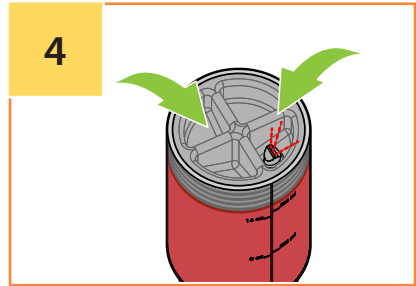

4

Priming

When using an empty pump, thread pump onto container and squeeze trigger to expel air. Your pump is then primed and ready to use.

NOTE: If pump is filled with product the priming step is not necessary.

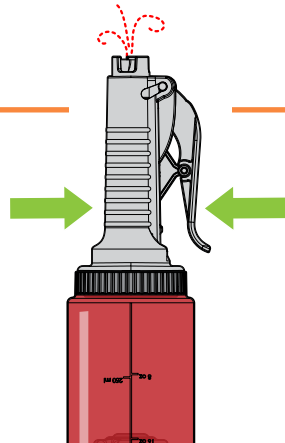

Changing Portion Size

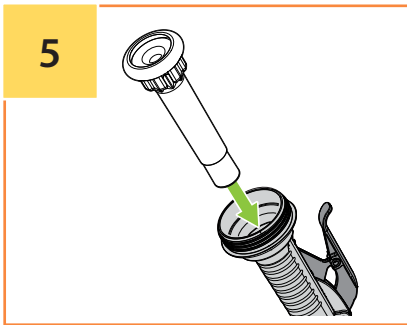
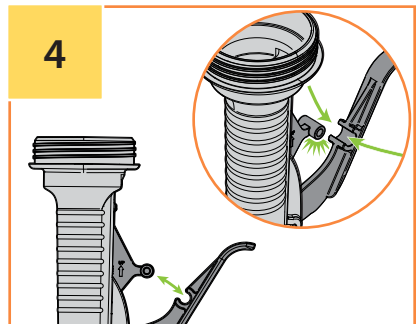
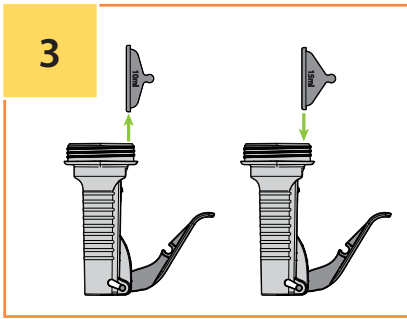
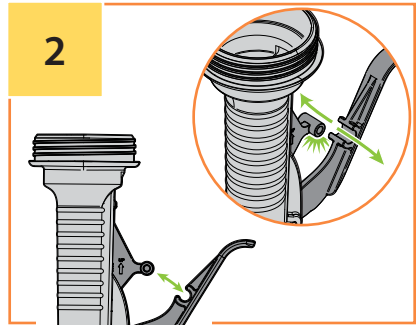
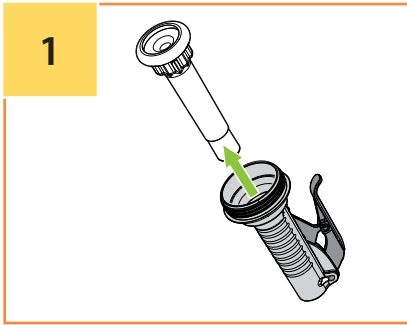

Portion Size

- ml*
- 3.75
- 5
- 7.5
- 10
- 15
- 20

*Approximate portion based on **Standard products** (ketchup or mustard).

Thick products (mayo, honey) may yield 2 ml less per portion.

Thin products (hot sauce, soy sauce) may yield 2 ml more per portion.

ASEPT General Warranty

Liability for defects

Should the products, as delivered, within one (1) year from delivery be shown to be defective due to defaults in material or manufacturing ("Warranty Period"), the Supplier undertakes, at its own option (i) to make a replacement delivery, (ii) to repair or rework the products claimed to be defective or (iii) to accept return of such product and refund such proportion of the purchase sum received as corresponds to the returned products. The Supplier assumes no liability for defects as regards to layout and design of the products, unless expressly stated in the Agreement.

The Customer shall without undue delay notify the Supplier in writing of any defect which appears. Such notice shall under no circumstances be given later than two (2) weeks after the expiry of the Warranty Period.

The Supplier is liable only for defect which appear under the conditions of operation provided for in the Agreement and under proper use of the product. The Supplier's liability does not cover defect which are caused by faulty maintenance, incorrect use or faulty repair by the Customer, or by alterations carried out without the Supplier's consent in writing. Finally, the Supplier's liability does not cover normal wear and tear or deterioration.

Except as expressly specified above, the Supplier has no liability for defects in the products whatsoever and are under no circumstances responsible for any direct or indirect losses, damages or costs incurred by the Customer, including consequential damages.

General limitation of liability

Notwithstanding any other limitation of liability mentioned in the Agreement including these Terms and Conditions, the Supplier's liability for damages under the Agreement shall be limited to the insurance compensation that can be obtained in accordance with the Supplier's each valid liability insurance.

Consequential losses

There shall be no liability of either party towards the other party for loss of production, loss of profit, loss of use, loss of contract or for any other consequential or indirect loss whatsoever.

ASEPT

ASEPT International Inc.

12100 W. Wirth St. Suite 300
Wauwatosa, WI 53222, USA
888-927-3785
info.us@asept.com

ASEPT International AB

Traktorvägen 17, SE-226 60
Lund, Sweden
+46 46 329 700
info@asept.com

www.asept.com