

ASEPT™

The Dispensing
Specialist



UNI DISPENSERS

User Manual

MODEL UNI-2, UNI-3
10233, 10232,
10641, 10642, 10643

UNI Dispensers

Complete Pump 9851 (Natural Dome)

Complete Pump 9855 (Black Dome)

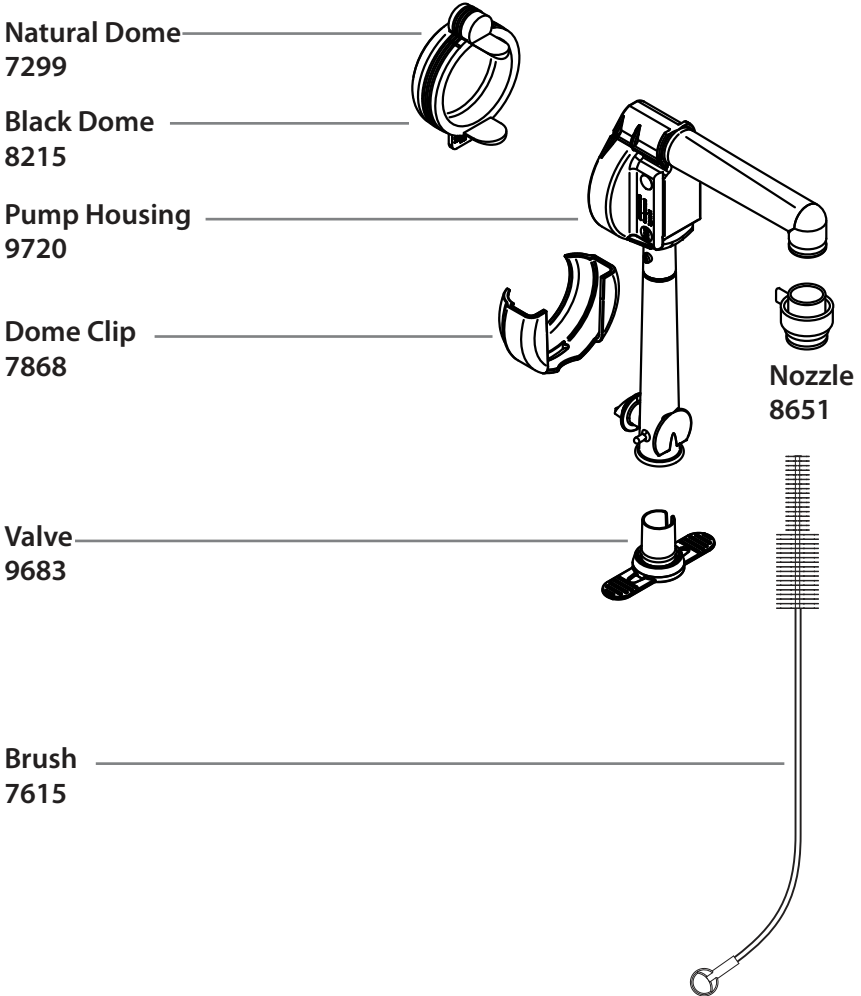

Designed for use with standard 1½, 1 or ¾ gallon pouched condiments and toppings.

Pumps attach to 16mm fitments in pouches.



Safety

All components must be cleaned before first use.



According to food and safety regulations, most foods must be stored and/or served at certain temperatures or they could become hazardous. Check with local food and safety regulators for specific guidelines. Be aware of the product you are serving and the temperature the product is required to maintain.

IMPORTANT Clean, rinse, sanitize, and dry parts at a minimum of every 24 hours. Always comply with local sanitization requirements.

Pump Cleaning

Disassemble all five (5) parts. Clean with soap and hot water, rinse, sanitize and dry parts according to local sanitization requirements. Use supplied brush to scrub inside parts.



All pump components are dishwasher safe.

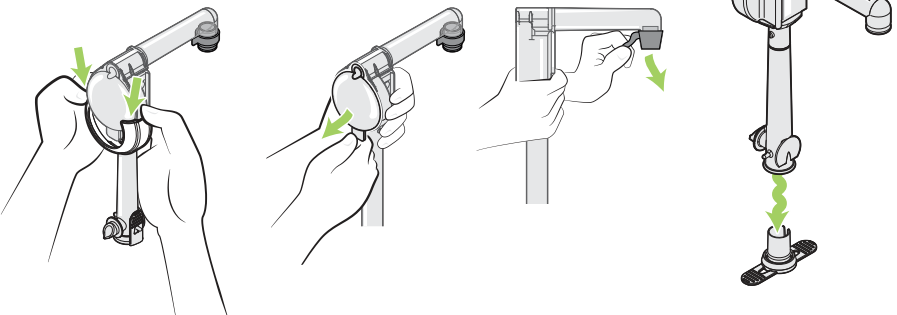

Clean and sanitize exterior of shroud as needed.

Assembly

1

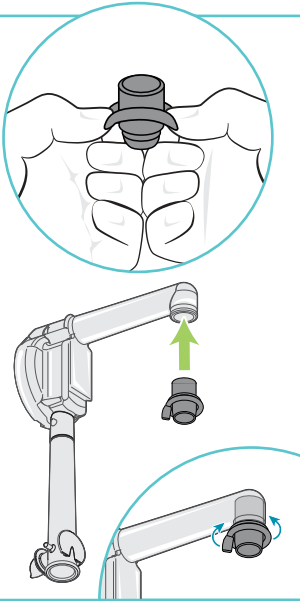

Mount the nozzle

onto the end of the pump housing. Bend the outer portion of the nozzle inside out.

Insert into opening. Tab of nozzle faces towards housing. Flip the outer portion of the nozzle over the end of tube.

2

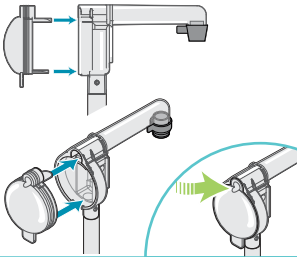

Insert dome

into the pump housing.

Ensure the flaps slide into place.

Press the entire dome firmly, including the top portion.

3

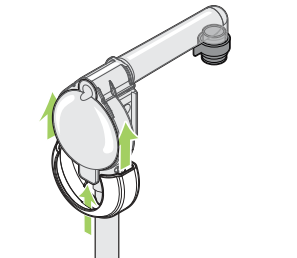

Insert the dome clip

over the dome and pump housing.

Ensure that the tab on bottom of the dome slides into the opening in the dome clip.

4

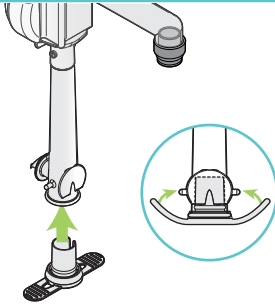

Insert valve

into the bottom of the pump housing. Wrap the flaps on the side of valve onto the pair of pegs on the pump housing.

TIP: Lubricate parts with clean water to ease fitting.

5

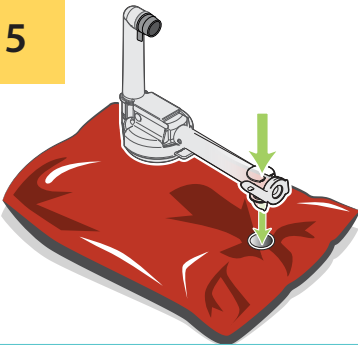

Connect pump to pouch

Put new pouch on countertop with fitment facing up. Place piercing end of connector in center of the fitment. Push firmly until pump snaps into place. Hold pouch up and push dome to prime pump.

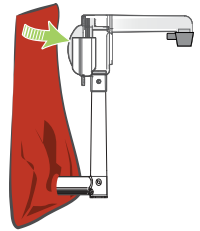

6

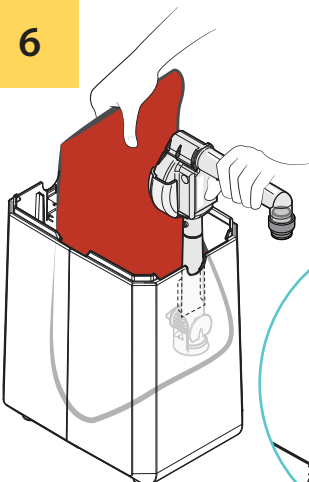

Insert pouch and pump

into the dispenser shroud. Hold end of pouch up while guiding the pump into the slots inside the front of dispenser. Suspend top of pouch with clip inside shroud.

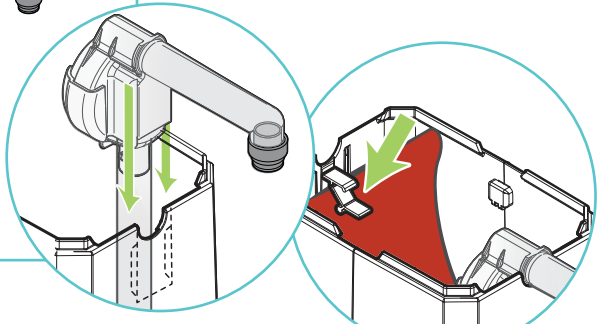

7

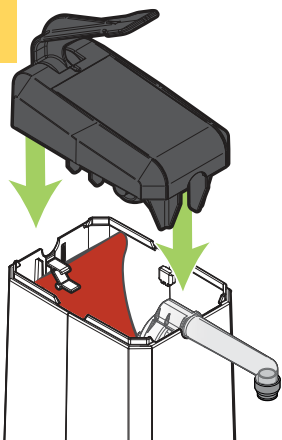

Insert the lid

Hold the lever up while inserting lid tabs into slots in back of dispenser shroud.

8

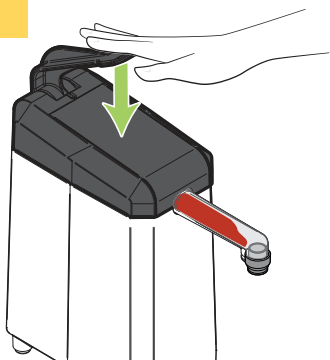

Prime pump

Press the pump lever several times until food is visible in discharge tube.

Tips & Troubleshooting

Product not dispensing?

Make sure dome is primed properly.

Prevent leaks:

Ensure that dome is pushed fully into pump housing.

Ensure that you hear a CLICK when attaching pump to pouch.

Pro Tip: Clean water may be used as lubrication when fitting valve onto pump housing.

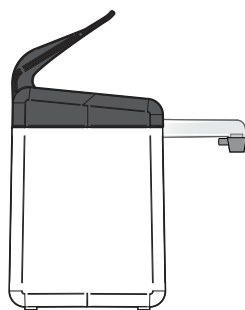

Setting the Portion

1

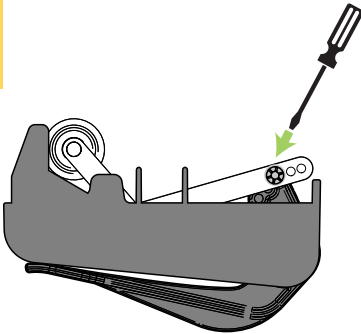

Remove locking washer

Use a flathead screwdriver to pry off the locking washer from the pin at the end of the link arms. Keep locking washer for step 4.

2

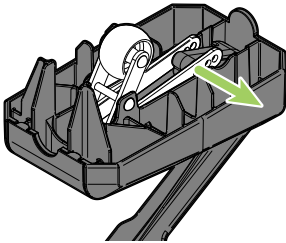

Remove pin

Slide the pin out from the pair of link arms and handle holes.

3

Link Arm Position

A B C

Handle Position

3
2
1

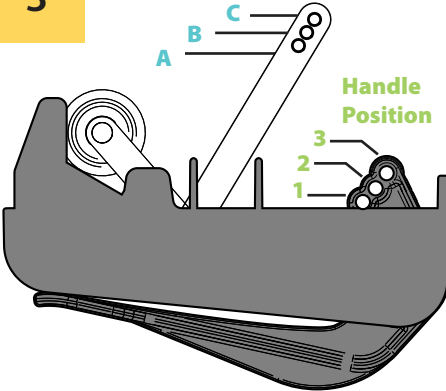

Select portion setting

Portion (fl. oz.)	Portion (ml)	Link Arm Position	Handle Position
1.75	52.0	A	3
1.33	39.0	A	2
1.00	30.0	B	3
0.75	22.5	A	1
0.66	19.5	B	2
0.50	15.0	C	3
0.25	7.5	C	2
0.25	7.5	B	1
0.03	1.0	C	1

4

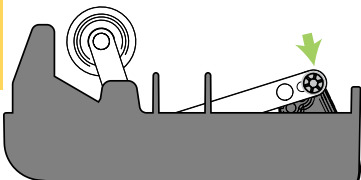

Align holes on handle and link arms

with holes for desired portion setting. Slide pin through all. Secure pin with locking washer.

ASEPT General Warranty

Liability for defects

Should the products, as delivered, within one (1) year from delivery be shown to be defective due to defaults in material or manufacturing ("Warranty Period"), the Supplier undertakes, at its own option (i) to make a replacement delivery, (ii) to repair or rework the products claimed to be defective or (iii) to accept return of such product and refund such proportion of the purchase sum received as corresponds to the returned products. The Supplier assumes no liability for defects as regards to layout and design of the products, unless expressly stated in the Agreement.

The Customer shall without undue delay notify the Supplier in writing of any defect which appears. Such notice shall under no circumstances be given later than two (2) weeks after the expiry of the Warranty Period.

The Supplier is liable only for defect which appear under the conditions of operation provided for in the Agreement and under proper use of the product. The Supplier's liability does not cover defect which are caused by faulty maintenance, incorrect erection or faulty repair by the Customer, or by alterations carried out without the Supplier's consent in writing. Finally, the Supplier's liability does not cover normal wear and tear or deterioration.

Except as expressly specified above, the Supplier has no liability for defects in the products whatsoever and are under no circumstances responsible for any direct or indirect losses, damages or costs incurred by the Customer, including consequential damages.

General limitation of liability

Notwithstanding any other limitation of liability mentioned in the Agreement including these Terms and Conditions, the Supplier's liability for damages under the Agreement shall be limited to the insurance compensation that can be obtained in accordance with the Supplier's each valid liability insurance.

Consequential losses

There shall be no liability of either party towards the other party for loss of production, loss of profit, loss of use, loss of contract or for any other consequential or indirect loss whatsoever.

ASEPT

Asept International Inc.

900 Oakmont Ln, Suite 207,
Westmont IL 60559, USA
888-927-3785
info.us@asept.com

Asept International AB

Traktorvägen 17, SE-226 60
Lund, Sweden
+46 46 329 700
info@asept.com

www.asept.com