

ASEPT™

The Dispensing Specialist

TOPPING PUMP

**One size fits all. Ease of use.
Low cost of ownership.**

This versatile pump dispenses a wide range of food products: thin syrups and hot sauces, thick ketchup and mayonnaise and products with particulates like tartar sauce and fruit purees.

The flexible pick up tube allows you to use the same pump in 7, 7 ½ and 10 inch fountain jars. Accurate portion control delivers consistent flavor profiles and reduced waste from over-portioning.

Transparent body makes for quick product identification. It's easy to break down, clean and reassemble. Available to dispense from a variety of open vessels or pouches for a sealed system that minimizes cleanup time.

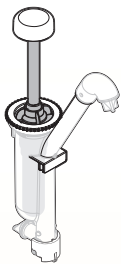

10600
for 16mm pouch

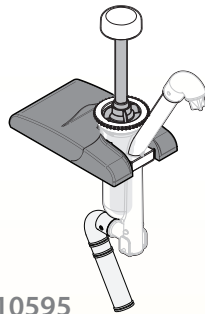

10595
for fountain jar



Features & Benefits

- NSF Listed
- Few components - easy to disassemble and clean
- No wear parts that require regular replacement
- All components are dishwasher safe
- Portion settings available from 1/4—3/4 fl oz
- Consistent portion control
- Transparent nozzles and optional color-coded knobs for easy product identification

Topping Pumps are designed for use with 48 or 64 oz pouches with 16mm fits or 7–10" fountain jars.



(Jars sold separately.)



TOPPING PUMP

Specifications

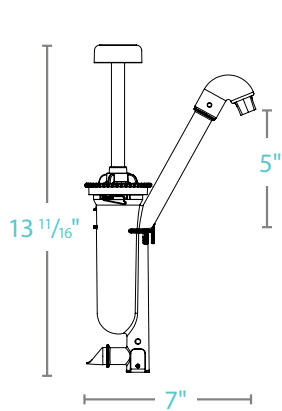

10600 (for 16mm pouch)

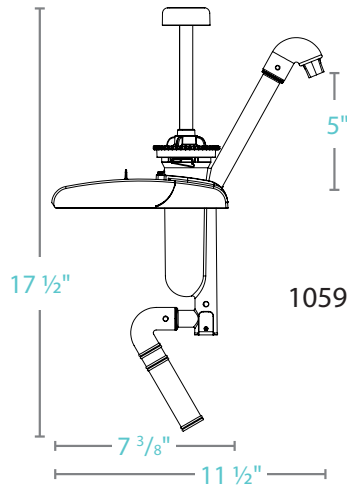

10595 (for fountain jar)



Part #	Description	Model	Weight	Dimensions (w x d x h)
10600	Topping Pump, 16mm	06	0.9 lbs	2 3/4 x 7 x 13 11/16
10595	Topping Pump, fountain jar	06	1.1 lbs	4 1/2 x 11 1/2 x 17 1/2
300251	Topping Pump Rail, Single	TR-TP1	4.2 lbs	18 1/2 x 5 3/4 x 12 3/8
300252	Topping Pump Rail, Double	TR-TP2	7 lbs	18 1/2 x 10 3/4 x 12 3/8
300253	Topping Pump Rail, Triple	TR-TP3	9.9 lbs	18 1/2 x 15 x 12 3/8
300254	Topping Pump Rail, Quadruple	TR-TP3	12.8 lbs	18 1/2 x 19 1/2 x 12 3/8

Accessories

ASEPT fountain jars work seamlessly with the topping pump. The sloped interior reduces waste up to 50% compared to other jars. These stable, sturdy units provide a standalone solution for countertops- no need for a separate containment system.

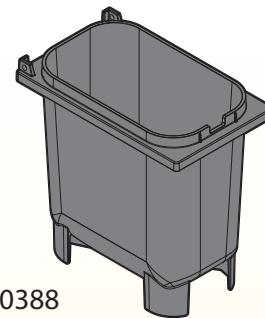

10388
Fountain Jar,
7 1/2" high

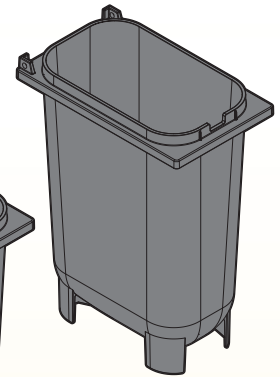

10389
Fountain Jar,
10" high

ASEPT

Asept International Inc.

5207 N. 125th St. Butler, WI 53007, USA
888-927-3785
info.us@asept.com

Asept International AB

Traktorvägen 17, SE-226 60 Lund, Sweden
+46 46 329 700
info@asept.com

www.asept.com

ASEPT™